

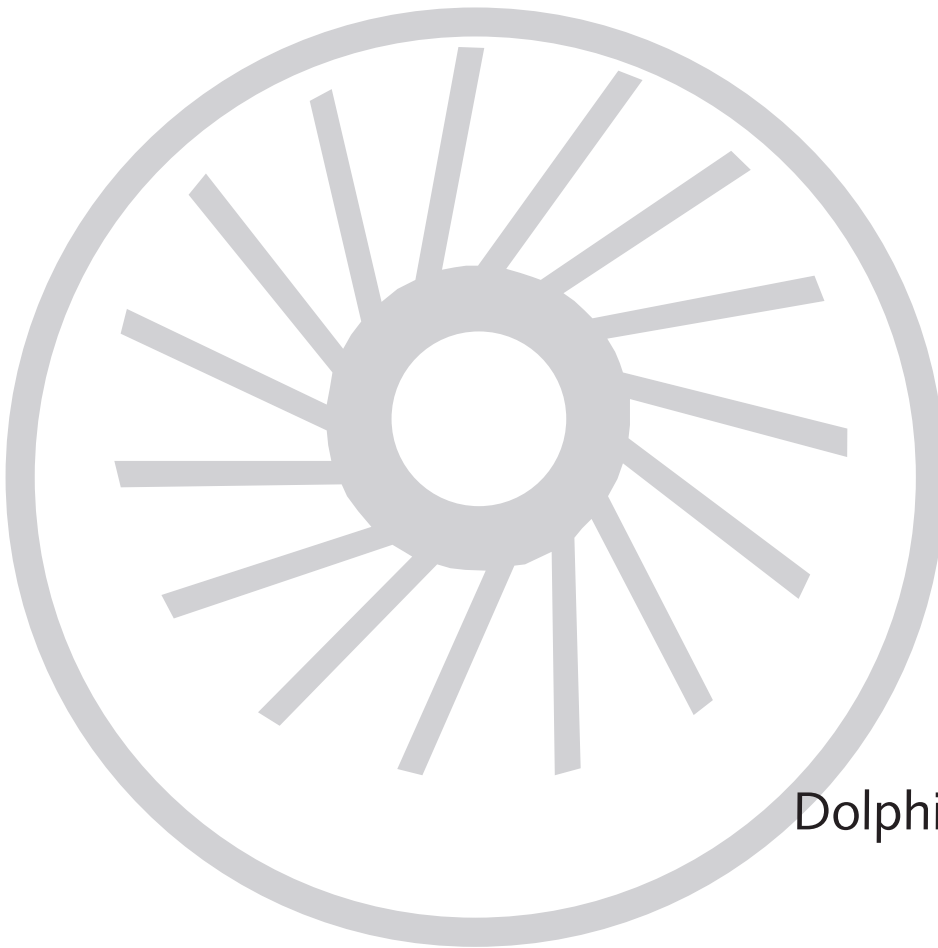

Installation and Operating Instructions



Vacuum Pumps
Dolphin LX 0030-0430 B



Busch GVT Ltd.
Unit A
Westmere Drive
Crewe
CW1 6ZD England

Table of Contents

Preface	2
Product Description	3
Use	3
Principle of Operation	3
Cooling	3
Start Controls	4
Safety	4
Intended Use	4
Safety Notes	4
Noise Emission	4
Transport	4
Transport in Packaging	4
Transport without Packaging	4
Storage	4
Short-term Storage	4
Conservation	4
Installation and Commissioning	5
Installation Prerequisites	5
Ancillary Conditions	5
Layout Proposals	5
Legend:	5
Once Through Operation / No Recovery	6
Partial Recovery	6
Closed Circuit Cooling / Total Recovery	7
Mounting Position and Space	7
Suction Connection	8
Gas Discharge	8
Electrical Connection / Controls	8
Installation	8
Mounting	8
Connecting Electrically	8
Connecting Lines/Pipes	8
Filling in Operating Liquid	8
Recording of Operational Parameters	8
Operation Notes	9
Use	9
Setting Operating Conditions	9
Selection of Operating Liquid	9
Fresh Water Requirement	9
Operating Liquid Level	9
Pressure Control	9
Removing Contaminations and Deposits	10
Maintenance	10
Maintenance Schedule	10
Monthly:	10
Every 6 Months:	10
Every Year:	10
Dismantling and Reassembly	10
Dismantling	10
Reassembly	10
Overhaul	11
Removal from Service	11
Temporary Removal from Service	11
Recommissioning	11
Dismantling and Disposal	11
Spare Parts	11
Troubleshooting	12
EC-Declaration of Conformity	15
Sectional Drawings and Spare Parts Lists	16
LX 0030 B to LX 0055 B	16
LX 0110 B to LX 0430 B	17
Technical Data	18
Busch – All over the World in Industry	19

Preface

Congratulations on your purchase of the Busch vacuum pump. With watchful observation of the field's requirements, innovation and steady development Busch delivers modern vacuum and pressure solutions worldwide.

These operating instructions contain information for

- product description,
- safety,
- transport,
- storage,
- installation and commissioning,
- maintenance,
- overhaul,
- troubleshooting and
- spare parts

of the vacuum pump.

The operating liquid supply system is either subject to a separate documentation or to be furnished by the operator.

For the purpose of these instructions, "handling" the vacuum pump means the transport, storage, installation, commissioning, influence on operating conditions, maintenance, troubleshooting and overhaul of the vacuum pump.

Prior to handling the vacuum pump these operating instructions shall be read and understood. If anything remains to be clarified please contact your Busch representative!

Keep these operating instructions and, if applicable, other pertinent operating instructions available on site.

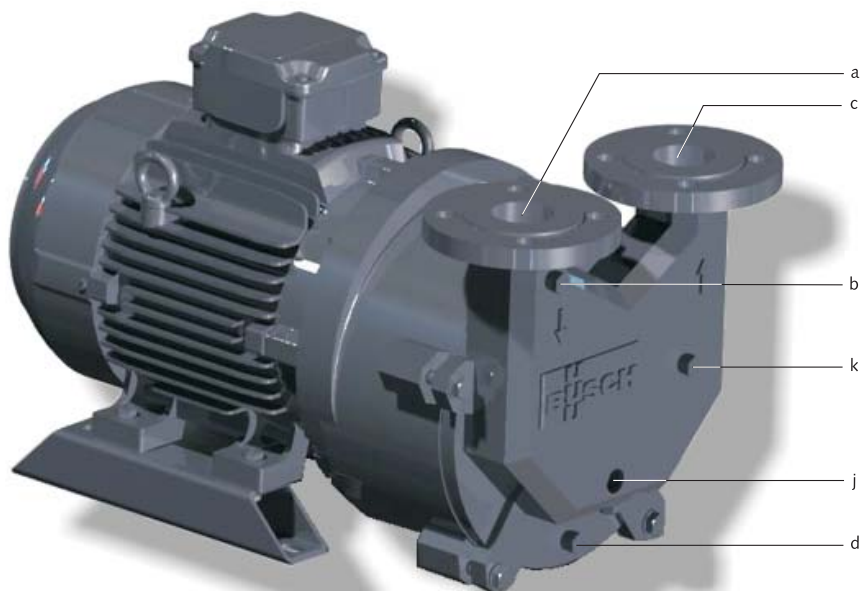

- a Suction connection
- b Anti-cavitation connection
- c Gas discharge
- d Drain
- e Suction port
- f Discharge port
- g Housing
- h Impeller
- i Liquid ring
- j Service liquid inlet
- k Centreline drain

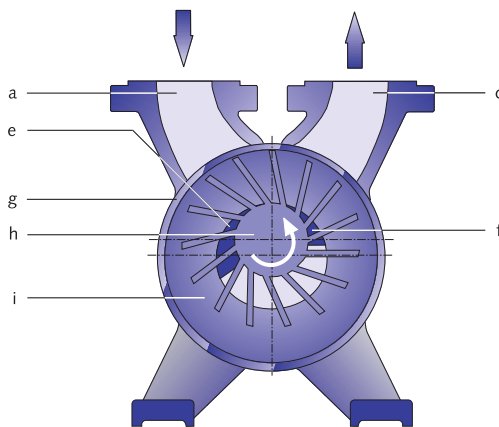

Product Description

Use

The vacuum pump is intended for

- the suction of
- non-explosive gases and vapours

The vacuum pump may only be used as contractually agreed with Busch. The conveyed medium, the operating liquid and the temperature ranges thereof may not be changed without written consent of Busch.

Maximum allowed temperatures:

gas dry:	100 °C
gas saturated:	80 °C
operating liquid:	40 °C

The vacuum pump is intended for the placement in a non-potentially explosive environment.

The vacuum pump is thermally suitable for continuous operation (100 percent duty).

The vacuum pump is not ultimate pressure proof. Operation with a closed ("blanked") suction line will damage the vacuum pump.

Principle of Operation

The vacuum pump works on the fluid ring principle.

At standstill, the pump housing (g) shall be filled with an operating liquid (usually water) to approx. the shaft centreline. On starting the vacuum pump, the impeller throws the liquid to the periphery of the housing, where it forms a liquid ring that rotates in the pump housing. This liquid ring seals the space between the impeller (h) and the housing (g). In the 12 o'clock position the liquid ring touches the hub of the impeller (h). As the impeller rotates counterclockwise (view from non-drive end), the liquid ring moves away from the hub, making space for gas to be drawn in through the intake port (e) (approx. from the 11 o'clock to the 8 o'clock position). The chamber surrounded by the hub, the liquid ring and two adjacent impeller blades achieves its maximum volume in the 6 o'clock position. As the impeller continues to rotate, the liquid ring moves closer to the impeller hub, the volume of the chamber decreases and the enclosed gas is expelled through the discharge port (f) (approx. from the 3 o'clock position to the 12 o'clock position). This sequence is repeated for every chamber between two impeller blades with each revolution.

The operating liquid also absorbs the heat of compression and condensation (when conveying saturated media).

The control of the level and the temperature of the operating liquid are essential for the satisfactory operation of the vacuum pump. The chapter Installation Prerequisites (→ page 5) gives advice and explains typical installation options.

Cooling

The vacuum pump is cooled by

- the air flow from the fan wheel of the drive motor
- the process gas
- the operating liquid

Start Controls

The vacuum pump comes without start controls. The control of the vacuum pump is to be provided in the course of installation.

Safety

Intended Use

Definition: For the purpose of these instructions, "handling" the vacuum pump means the transport, storage, installation, commissioning, influence on operating conditions, maintenance, troubleshooting and overhaul of the vacuum pump.

The vacuum pump is intended for industrial use. It shall be handled only by qualified personnel.

The allowed media and operational limits (→ page 3: Product Description) and the installation prerequisites (→ page 5: Installation Prerequisites) of the vacuum pump shall be observed both by the manufacturer of the machinery into which the vacuum pump is to be incorporated and by the operator.

The maintenance instructions shall be observed.

Prior to handling the vacuum pump these installation and operating instructions shall be read and understood. If anything remains to be clarified please contact your Busch representative!

Safety Notes

The vacuum pump has been designed and manufactured according to state-of-the-art methods. Nevertheless, residual risks may remain. These operating instructions highlight potential hazards where appropriate. Safety notes are tagged with one of the keywords DANGER, WARNING and CAUTION as follows:



DANGER

Disregard of this safety note will always lead to accidents with fatal or serious injuries.



WARNING

Disregard of this safety note may lead to accidents with fatal or serious injuries.



CAUTION

Disregard of this safety note may lead to accidents with minor injuries or property damage.

Noise Emission

For the sound pressure level in free field according to EN ISO 2151 → page 18: Technical Data.

Transport

Transport in Packaging

Packed on a pallet the vacuum pump is to be transported with a forklift.

Transport without Packaging

In case the vacuum pump is packed in a cardboard box with inflated cushions:

- ◆ Remove the inflated cushions from the box

In case the vacuum pump is in a cardboard box cushioned with rolled corrugated cardboard:

- ◆ Remove the corrugated cardboard from the box

In case the vacuum pump is laid in foam:

- ◆ Remove the foam

In case the vacuum pump is bolted to a pallet or a base plate:

- ◆ Remove the bolting between the vacuum pump and the pallet/base plate

In case the vacuum pump is fastened to the pallet by means of tightening straps:

- ◆ Remove the tightening straps



CAUTION

Do not walk, stand or work under suspended loads.

- Attach the lifting gear to a crane hook with safety latch
- Lift the vacuum pump with a crane

In case the vacuum pump was bolted to a pallet or a base plate:

- ◆ Remove the stud bolts from the rubber feet

Storage

Short-term Storage

- Make sure that the suction connection and the gas discharge are closed (leave the provided plugs in)
- Store the vacuum pump
 - if possible in original packaging,
 - indoors,
 - dry,
 - dust free and
 - vibration free

Conservation

In case of adverse ambient conditions (e.g. aggressive atmosphere, frequent temperature changes) conserve the vacuum pump immediately. In case of favourable ambient conditions conserve the vacuum pump if a storage of more than 3 months is scheduled.

- Make sure that all ports are firmly closed; seal all ports that are not sealed with PTFE-tape, gaskets or o-rings with adhesive tape

Note: VCI stands for "volatile corrosion inhibitor". VCI-products (film, paper, cardboard, foam) evaporate a substance that condenses in molecular thickness on the packed good and by its electro-chemical properties effectively suppresses corrosion on metallic surfaces. However, VCI-products may attack the surfaces of plastics and elastomers. Seek advice from your local packaging dealer! Busch uses CORTEC VCI 126 R film for the overseas packaging of large equipment.

- Wrap the vacuum pump in VCI film
- Store the vacuum pump
 - if possible in original packing,
 - indoors,
 - dry,
 - dust free and
 - vibration free.

For commissioning after conservation:

- Make sure that all remains of adhesive tape are removed from the ports
- Commission the vacuum pump as described in the chapter Installation and Commissioning (→ page 5)

Installation and Commissioning

Installation Prerequisites



CAUTION

In case of non-compliance with the installation prerequisites, particularly in case of insufficient cooling:

Risk of damage or destruction of the vacuum pump and adjoining plant components!

Risk of injury!

The installation prerequisites must be complied with.

- Make sure that the integration of the vacuum pump is carried out such that the essential safety requirements of the Machine Directive 2006/42/EC are complied with (in the responsibility of the designer of the machinery into which the vacuum pump is to be incorporated; → page 15: note in the EC-Declaration of Conformity)

Ancillary Conditions

The chapter Principle of Operation (→ page 3) describes the basic function of a vacuum pump. This description assumes, that the liquid ring stays liquid all the time.

Actually the condition of both the operating liquid and the conveyed media depend on the physical conditions pressure and temperature.

At very low pressures and sufficiently high temperatures the operating liquid can locally transfer into the vapour phase, creating bubbles within the operating liquid. As the pressure rises towards the outlet port (e) the bubbles collapse. This process is called cavitation. In case of bubbles that have been located on surfaces the operating liquid cannot intrude the cavity left by the bubble equally from all directions. Instead the inflowing liquid hits the surface with high speed. This causes erosion, which can destroy the vacuum pump rapidly. Also the formation of bubbles deteriorates the pump performance. Cavitation is clearly audible by its rumbling noise.

For a trouble-free operation the vacuum pump shall be filled with operating liquid approx. up to the shaft centre before the pump is switched on. A low liquid level deteriorates the pump performance. A dry start causes failure of the mechanical seal on the shaft of the vacuum pump. A start with a completely flooded housing damages the blades of the impeller.

Once the vacuum pump is running operating liquid can be supplied. Excess operating liquid will then be thrown out through the outlet. The pressure of the supplied operating liquid shall not exceed the outlet pressure of the vacuum pump by more than 0.1 bar, otherwise the pump performance will deteriorate. The best solution is a reservoir under atmospheric pressure from which the vacuum pump sucks in operating liquid automatically.

The pressure control and the operating liquid supply system of a vacuum pump must therefore fulfill the following tasks:

- limit the operating pressure to a value at which no cavitation will occur
- control the level in the operating liquid separator and if appropriate, cool the operating liquid to a temperature at which no cavitation will occur

Operating the vacuum pump close to its ultimate pressure requires large quantities of cool operating liquid. In order to avoid cavitation it is usually more prudent to limit the minimum working pressure.

The pressure on the suction side of the vacuum pump must not fall below the minimum allowed operating pressure. Therefore it is not allowed to use a pressure control the actuator of which would throttle or even close the suction line.

The most effective measure to limit the inlet pressure is the use of a vacuum relief valve.

The vacuum relief valve can either be installed in the suction line or on the housing of the vacuum pump. The gas supply line of the vacuum relief valve is usually connected to the liquid separator. Alternatively ambient air can be used to limit the vacuum.

Feeding ambient air cools, acts against condensation or solution of process gas in the operating liquid and therefore reduces the risk of cavitation, however, it mixes the process gas with ambient air, i.e. with oxygen, which is possibly not desired. Drawing air from the liquid separator avoids mixing with ambient air, however, this air is usually warmer, promotes the accumulation of condensed or solved process gas in the operating liquid, hence increasing the risk of cavitation. If the primary task is to suck vapours, a non-condensing gas should be selected for the admixing.

Layout Proposals

The working principle of the liquid ring is dependent upon a continuous supply of clean operating liquid, which is normally water. The operating liquid enters the Vacuum pump/ Compressor/ Vacuum and pressure pump/ Blower through a connection B on the housing and is discharged from the Vacuum pump/ Compressor/ Vacuum and pressure pump/ Blower along with the process gas.

For the layout of an operating fluid supply system there are basically three different models:

- Once through cooling / no recovery
- partial recovery
- closed loop / total recovery

All of these arrangements have four basic elements:

- Source of the operating liquid (from the water main or reservoir)
- Regulating device to control flow of liquid
- Means of stopping the flow when the Vacuum pump/ Compressor/ Vacuum and pressure pump/ Blower is shut off (manual or with solenoid valve)
- Means of separating the gas-liquid exhaust mixture

Legend:

Note: The diagrams below show examples of typical installations. The actual scope of delivery is always contractually agreed upon. Consult the contract piping and instrument diagram for the exact scope of delivery.

A	Discharge liquid
B	Operating liquid
F	Fresh liquid
K	Cooling liquid
U	Circulation liquid
N	Liquid level
S	Process suction side
D	Process pressure side
P	Liquid ring-vacuum pump
P _B	Circulating pump
a	Liquid separator
b	Fresh liquid vessel
h	Aeration connection
w	Heat transmitter
V _B	Vacuum relief valve
V _F	Shut-off valve
V _K	Shut-off valve
V _S	Non-return valve
r _B	Regulating valve
r _C (=PC)	Regulating valve (anti-cavitation)
r _F	Regulating valve
r _{F1}	Regulating valve (float valve)
r _{F2}	Regulating valve (thermostatical)
r _{F3}	Regulating valve (pressure reducer)
r _K	Regulating valve (cooling water)
l _B	Operating liquid pipe
l _C	Anti-cavitation pipe (optional)
l _F	Fresh liquid pipe
l _K	Cooling liquid pipe
l _S	Suction pipe
l _D	Discharge pipe
l _U	Circulation pipe

- $m_a (=Li)$ Level indicator
- $m_B (=Pi)$ Compound (vacuum & pressure) gauge
- m_D Pressure gauge
- $m_t (=Ti)$ Thermometer
- m_{t1} Temperature sensor to r_{F2}
- U_A Liquid discharge
- U_B Connection for operating liquid
- U_S Suction pipe connection
- U_D Discharge pipe connection
- U_E Drain (liquid separator)
- U_e Drain (pump)
- U_U Connection for circulation liquid

Once Through Operation / No Recovery

The operating liquid is taken directly from a main supply to the vacuum pump. The operating liquid is separated from the gas and wasted to a drain. No recirculation or recovery takes place. This arrangement can be used where operating liquid conservation or contamination are not a concern. An automatic solenoid valve can provide for flow of operating liquid simultaneously with -vacuum pump operation (i.e. upon motor stopping, the valve closes preventing the housing to be filled with too much operating liquid). With a manual operating liquid shut off valve, it is **important** to open valve immediately after starting the motor and to close the valve immediately before switching the motor off.

Version with lateral liquid separator:

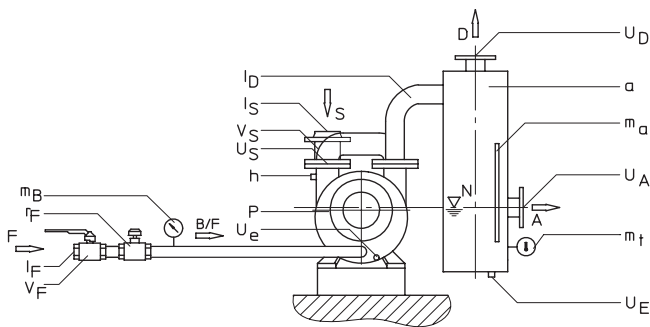

Version with top liquid separator:

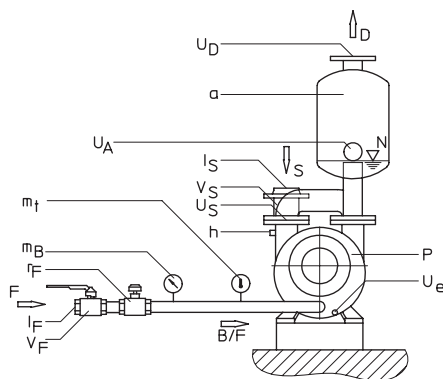

Circuit diagram:

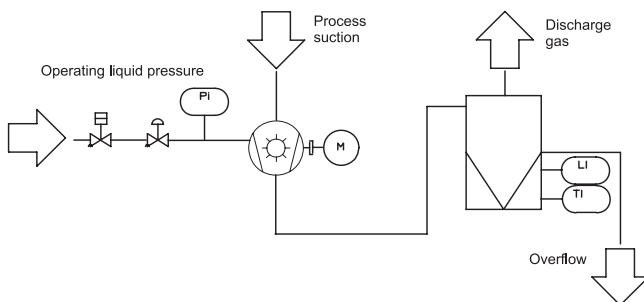

Alternative tank with float valve:

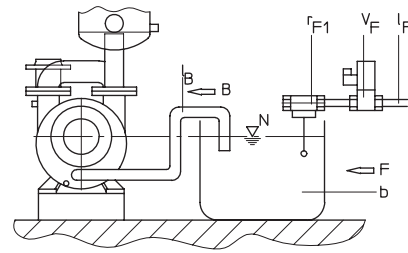

Partial Recovery

The operating liquid enters and leaves the vacuum pump in the same manner as with the once through arrangement. A portion of the operating liquid is recirculated from the separator tank to the vacuum pump. The remainder is discharged from the separator to the drain. The fresh liquid F is introduced in sufficient quantity to maintain proper temperature essential for good vacuum pump performance. This type of arrangement is used where seal liquid conservation is possible, and, if other than water is utilised, the consumption can be reduced by upto 50 percent depending upon the fluid vapour pressure and temperature.

The operating liquid level in the separator/recirculation tank should be at, or slightly below, the centreline of the pump shaft. Provisions may also be made for high level overflow. This will help prevent starting the vacuum pump with the housing full of water, which could overload the vacuum pump and the drive motor.

Version with lateral liquid separator:

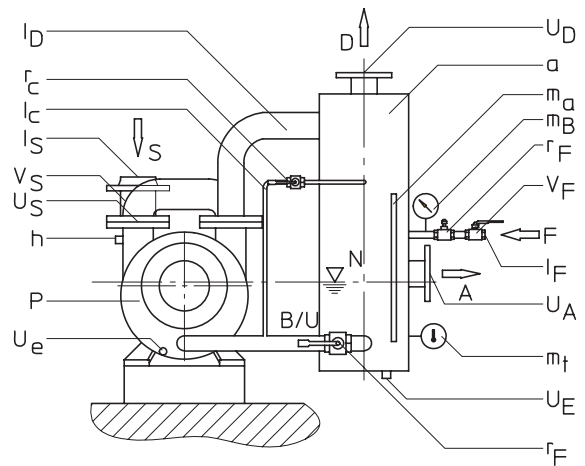

Version with top liquid separator:

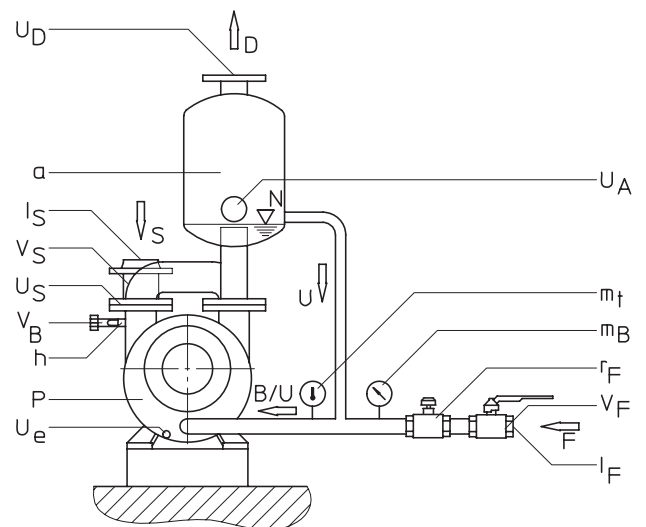

Circuit diagram:

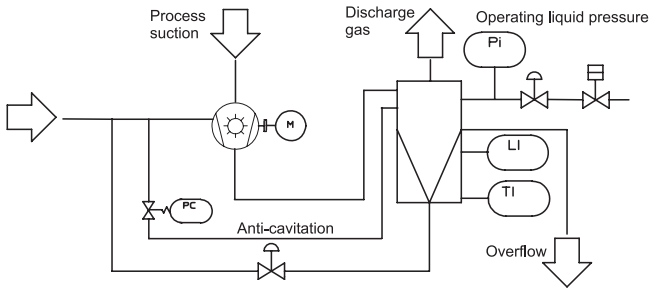

Alternative thermostatically controlled operating liquid temperature:

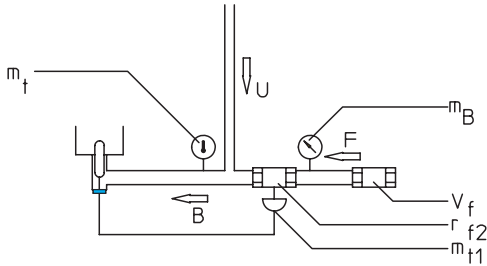

Closed Circuit Cooling / Total Recovery

This arrangement provides for total recirculation of the operating liquid. A heat exchanger is added to remove the heat of compression, friction and condensation from the operating liquid before it is re-introduced back into the vacuum pump. For prolonged operation at suction pressure above 300 hPa abs (300 mbar abs) a circulating pump is normally installed and mandatory at suction pressure above 400 hPa abs (400 mbar abs) or when suction pressure varies during cycling operations.

The operating liquid level in the separator/recirculation tank should be at, or slightly below, the centreline of the pump shaft. Provisions may also be made for high level overflow and low level make-up. This will help prevent starting the vacuum pump with the housing full of water, which could overload the vacuum pump and the drive motor.

The heat exchanger W must be capable of removing approx. 85 percent of the drive power and possibly appearing condensation heat. The heat exchanger can be waived, if the vacuum pump will be operated for a few minutes only and cool down to ambient temperature prior to the subsequent start.

Version with lateral liquid separator:

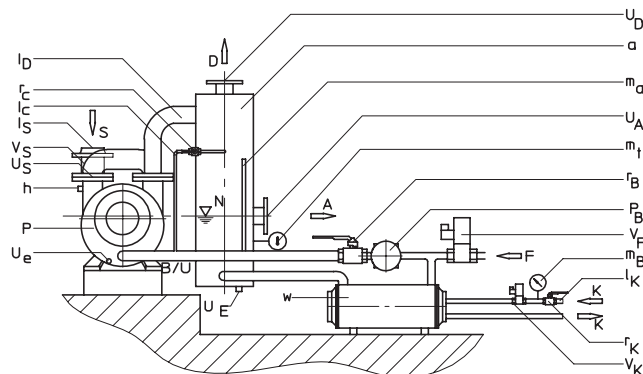

Version with top liquid separator:

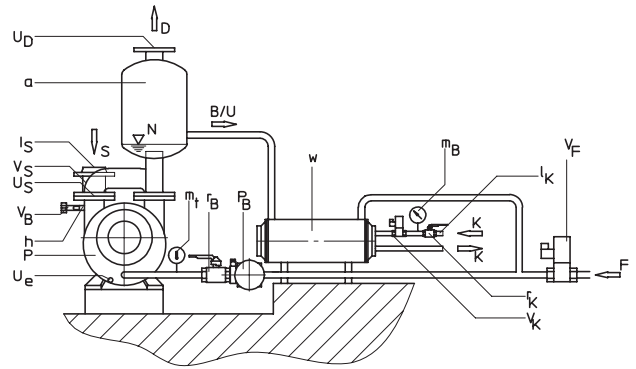

Circuit diagram:

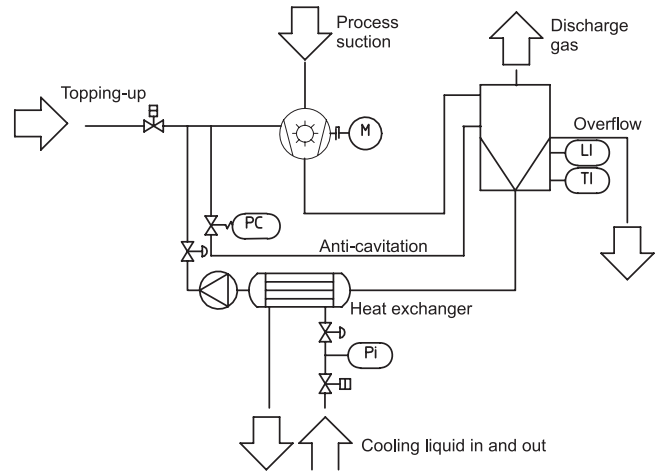

Mounting Position and Space

- Make sure that the following ambient conditions will be complied with:
 - ambient temperature: 5 ... 40 °C
 - ambient pressure: atmospheric
- Make sure that the environmental conditions comply with the protection class of the drive motor (according to the nameplate)
- Make sure that the vacuum pump will be placed or mounted horizontally
- Make sure that the base for placement / mounting base is even
- Make sure that in order to warrant a sufficient cooling there will be a clearance of minimum 0.1 m between the vacuum pump and nearby walls
- Make sure that no heat sensitive parts (plastics, wood, cardboard, paper, electronics) will touch the surface of the vacuum pump
- Make sure that the installation space or location is vented such that a sufficient cooling of the vacuum pump is warranted



CAUTION

During operation the surface of the vacuum pump may reach temperatures of more than 70 °C.

Risk of burns!

- Make sure that the vacuum pump will not be touched inadvertently during operation, provide a guard if appropriate

Suction Connection



CAUTION

Intruding foreign objects or liquids can destroy the vacuum pump.

In case the inlet gas can contain dust or other foreign solid particles:

- Make sure that the suction line fits to the suction connection (a) of the vacuum pump
- Make sure that the line size of the suction line over the entire length is at least as large as the suction connection (a) of the vacuum pump

In case the length of the suction line exceeds 2 m it is prudent to use larger line sizes in order to avoid a loss of efficiency and an overload of the vacuum pump. Seek advice from your Busch representative!

In case the vacuum shall be maintained after shutdown of the vacuum pump:

- ◆ Provide a manual or automatic operated valve (= non-return valve) in the suction line
- Make sure that the suction line does not contain foreign objects, e.g. welding scales

Gas Discharge

Version with top liquid separator:

The discharge piping should not exceed an elevation more than 600 mm above the discharge flange (c) of the pump housing until the liquid is separated. Too high an elevation will cause back pressure and possible drive motor overload.

The discharged gas must flow without obstruction. It is not permitted to shut off or throttle the discharge line or to use it as a pressurised air source.

- Make sure that the discharge line fits to the gas discharge (c) of the vacuum pump
- Make sure that the line size of the discharge line over the entire length is at least as large as the gas discharge (c) of the vacuum pump

In case the length of the discharge line exceeds 2 m it is prudent to use larger line sizes in order to avoid a loss of efficiency and an overload of the vacuum pump. Seek advice from your Busch representative!

- Make sure that the discharge line either slopes away from the vacuum pump or provide a liquid separator or a drip leg with a drain cock, so that no liquids can back up into the vacuum pump

Electrical Connection / Controls

- Make sure that the stipulations acc. to the EMC-Directive 2004/108/EC and Low-Voltage-Directive 2006/95/EC as well as the EN-standards, electrical and occupational safety directives and the local or national regulations, respectively, are complied with (this is the responsibility of the designer of the machinery into which the vacuum pump is to be incorporated; → page 15: note in the EC-Declaration of Conformity).
- Make sure that the power supply for the drive motor is compatible with the data on the nameplate of the drive motor
- Make sure that an overload protection according to EN 60204-1 is provided for the drive motor
- Make sure that the drive of the vacuum pump will not be affected by electric or electromagnetic disturbance from the mains; if necessary seek advice from the Busch service

In case of mobile installation:

- ◆ Provide the electrical connection with grommets that serve as strain-relief

Installation

Mounting

- Make sure that the Installation Prerequisites (→ page 5) are complied with
- Set down or mount the vacuum pump at its location

Connecting Electrically



WARNING

Risk of electrical shock, risk of damage to equipment.

Electrical installation work must only be executed by qualified personnel that knows and observes the following regulations:

- IEC 364 or CENELEC HD 384 or DIN VDE 0100, respectively,
- IEC-Report 664 or DIN VDE 0110,
- BGV A2 (VBG 4) or corresponding national accident prevention regulation.

- Electrically connect the drive motor
- Connect the protective earth conductor

Version with three-phase motor:

- ◆ Determine the intended direction of rotation with the arrow (stuck on or cast)

Version with mechanical seal:

- Make sure that the pump housing (g) is filled with an operating liquid (usually water) to approx. the shaft centreline (a mechanical seal shall not run dry)
 - ◆ "Bump" the drive motor
 - ◆ Watch the fan wheel of the drive motor and determine the direction of rotation just before the fan wheel stops

If the rotation must be changed:

- ◆ Switch any two of the drive motor wires (three-phase motor)

- Connect the switches for
 - level monitoring
 - temperature
 - pressure (according to the diagram) to the system control

Connecting Lines/Pipes

- Connect the suction line
- Connect the discharge line

Installation without discharge line:

- ◆ Make sure that the gas discharge (c) is open
- Make sure that all provided covers, guards, hoods etc. are mounted
- Make sure that cooling air inlets and outlets are not covered or obstructed and that the cooling air flow is not affected adversely in any other way

Filling in Operating Liquid

The handling of the operating liquid supply system is not subject to these operating instructions (→ separate documentation or furnished by the operator).

Recording of Operational Parameters

As soon as the vacuum pump is operated under normal operating conditions:

- Measure the drive motor current and record it as reference for future maintenance and troubleshooting work

Operation Notes

Use

The vacuum pump is intended for

- the suction

of

- non-explosive gases and vapours

The vacuum pump may only be used as contractually agreed with Busch. The conveyed medium, the operating liquid and the temperature ranges thereof may not be changed without written consent of Busch.

Maximum allowed temperatures:

gas dry:	100 °C
gas saturated:	80 °C
operating liquid:	40 °C

The vacuum pump is intended for the placement in a non-potentially explosive environment.

The vacuum pump is thermally suitable for continuous operation (100 percent duty).

The vacuum pump is not ultimate pressure proof. Operation with a closed ("blanked") suction line will damage the vacuum pump.



CAUTION

During operation the surface of the vacuum pump may reach temperatures of more than 70 °C.

Risk of burns!

The vacuum pump shall be protected against contact during operation, it shall cool down prior to a required contact or heat protection gloves shall be worn.

- Make sure that all provided covers, guards, hoods etc. remain mounted
- Make sure that protective devices will not be disabled
- Make sure that cooling air inlets and outlets will not be covered or obstructed and that the cooling air flow will not be affected adversely in any other way
- Make sure that the installation prerequisites (→ page 5: Installation Prerequisites) are complied with and will remain complied with, particularly that a sufficient cooling will be ensured



CAUTION

The shaft of the vacuum pump is sealed by means of a mechanical seal.

Starting the vacuum pump without operating liquid will result in mechanical seal failure.

Never start the vacuum pump without operating liquid.

Setting Operating Conditions

Selection of Operating Liquid

Water is usually used as operating liquid for the conveyance of air and other inert gases. Other ring liquids may be used in order to comply with the selected gases and separation methods.

The kinematic viscosity at operating temperature shall not exceed 2 mm²/s. Higher viscosities require increased drive power. The vapour pressure of the ring fluid in case of vacuum operation shall not exceed 16 mbar. Higher vapour pressures deteriorate the suction capacity and the ultimate pressure as stated in the performance tables or curves resp. In case of use of ring liquids other than water confirmation of the vacuum pump's conveying characteristics shall be sought from Busch.

If liquids get conveyed together with the process gas (three to five times the quantity of the circulating liquid rate as given in the datasheet) the addition of fresh liquid can be reduced significantly.

Condensation of vapour inside the vacuum pump can cause cavitation and destroy components of the vacuum pump. Condensation upstream of the vacuum pump (jet or surface condenser) shall therefore be preferred. Under certain conditions the accumulating condensate can be conveyed along by the vacuum pump. Otherwise a separate liquid pump must be provided for. The design shall be performed by the manufacturer/supplier.

The suction capacity (or volume flow) as given in the performance table is achieved at an operating water temperature of 15 °C. Operation at higher water temperatures leads to a reduced suction capacity (or volume flow), but leaves the option to save fresh water or cooling liquid in case of open or closed circuit cooling. This liquid rate shall be set by means of the regulating valve r_F or r_B only to such a quantity, that the required suction capacity (or volume flow) is achieved. The regulating valve shall be locked in this position.

Fresh Water Requirement

Fresh water flow rate requirements are shown in the technical data section → page 18. The data given applies to once through operation.

These water flow rates result in approximately a 5.5 °C rise in temperature for a single stage vacuum pump, and a 2.7 °C rise for a two stage vacuum pump when handling dry air. Condensable vapours in the gas stream, however, will add to the heat load and cause a higher temperature rise through the vacuum pump.

Partial recovery flow rates may be reduced by up to 50 percent dependant upon temperature rise through the vacuum pump (see above comment).

If operating speed is varied from the given values, the flow rate requirements vary accordingly.

Operating Liquid Level

Note: The options to check the level depend on the installation. In case the installation provides no means for level check, undo the plug. Excess operating liquid will then flow out of the port. If necessary fill in operating liquid, until it reaches the bottom edge of the port. Reinsert the plug prior to starting the vacuum pump.



CAUTION

Starting the vacuum pump with a completely flooded housing can bend the blades of the rotor.

The operating liquid shall reach the middle of the shaft only when the vacuum pump is to be started.

- Make sure that the operating liquid reaches the middle of the shaft when the vacuum pump is to be started

Pressure Control

At very low pressures and sufficiently high temperatures the operating liquid can locally transfer into the vapour phase, creating bubbles within the operating liquid. As the pressure rises towards the outlet slot the bubbles collapse. This process is called cavitation. In case of bubbles that have been located on surfaces the operating liquid cannot intrude the cavity left by the bubble equally from all directions. Instead the inflowing liquid hits the surface with high speed. This causes erosion, which can destroy the vacuum pump rapidly. The formation of bubbles also deteriorates the pump performance. Cavitation is clearly audible by its crackling noise.

The working pressure of the vacuum pump shall therefore be sufficiently above the vapour pressure of the operating liquid. In particular the pressure control in the vacuum system must by no means be achieved by throttling or even closing of the suction line!

The vapour pressure of the operating liquid and consequently the ultimate pressure can be reduced by cooling. However, this increases the cooling water flow considerably. In most cases the low ultimate pressure is not required and cavitation shall be avoided by means of vacuum limitation rather than cooling.

Removing Contaminations and Deposits

- In closed operating liquid circuits with water use softened water
- Make sure that no dirt particles with a diameter larger than 0.1 mm will intrude the vacuum pump, neither via the process gas nor via the operating liquid. Filter out larger dirt particles before the vacuum pump.

The dirt concentration shall not exceed 5 volume percent.

Maintenance

DANGER

In case the vacuum pump conveyed gas that was contaminated with foreign materials which are dangerous to health, harmful material can reside in filters.

Danger to health during inspection, cleaning or replacement of filters.

Danger to the environment.

Personal protective equipment must be worn during the handling of contaminated filters.

Contaminated filters are special waste and must be disposed of separately in compliance with applicable regulations.

CAUTION

During operation the surface of the vacuum pump may reach temperatures of more than 70 °C.

Risk of burns!

- Prior to disconnecting connections make sure that the connected pipes/lines are vented to atmospheric pressure

Maintenance Schedule

Monthly:

- Check for audible abnormal noise, e.g.:
 - Excessive rumble (possible cavitation problem)
 - Periodic click/knock (possible mechanical contact / bearing degradation)

Version with mechanical seals:

- Mechanical seal squealing noise (possible lack of lubrication)
- Check for excessive vibration

Vibration should be less than 5.5 mm/s RMS when measured in the axial, vertical radial and vertical horizontal planes on the bearing housing.

High vibration could indicate fixing bolt looseness or bearing degradation.
- Check the operating liquid temperature (with a hand held probe or a permanent gauge, if fitted; consult the order documentation for the specified operating liquid temperature)
- Check the bearing temperature (with a hand held probe or a permanent gauge, if fitted; at 25 °C ambient temperature the bearing temperature should not exceed 60 °C (operating liquid = water) or 80 °C (operating liquid = oil); for other ambient temperatures adjust accordingly)
- Check that the vacuum pump achieves the usual/specified vacuum level
- Check all pipe work for leakage

Version with mechanical seals:

- Check the mechanical seals for leakage

- Make sure that the vacuum pump is shut down and locked against inadvertent start up

In case of operation in a dusty environment:

- ◆ Clean as described under → page 10: Every 6 Months:

Every 6 Months:

- Make sure that the housing is free from dust and dirt, clean if necessary
- Make sure that the vacuum pump is shut down and locked against inadvertent start up
- Clean the fan cowling, the fan wheel, the ventilation grille and the cooling fins

Every Year:

- Make sure that the vacuum pump is shut down and locked against inadvertent start up

In case an inlet screen is installed:

- ◆ Check the inlet screen, clean if necessary

Dismantling and Reassembly

Note: Complete disassembly is seldom necessary and the vacuum pump need only be disassembled to the point required to repair or service it.

See the sectional drawings for cross-reference.

Dismantling

- Disconnect from electrical supply and process piping
- Drain as much operating liquid from the vacuum pump as possible
- Remove the end casing (106.7) and port plate (137.1) assembly
- Remove countersunk screw (906.2) and free the port plate (137.1) from the end casing (106.7)
- Remove sealing nut (920.5)
- Remove nut (920.0) - not fitted to pump type LX0110
- Remove adjusting nut (907.0) and stud (902.0)

Reassembly

The vacuum pump is built up in reversal of the dismantling instructions.

- Clean all parts thoroughly before commencing rebuild
- Fit mechanical seal stationary seat into impeller casing and then fit casing to the motor
- Fit stud into motor shaft end, ensuring longest thread is protruding
- Fit the mechanical seal rotary face onto the impeller and slide the impeller onto the motor shaft until the impeller touches the casing
- Screw adjusting screw into the impeller. With a straight edge across the front of the impeller casing and impeller, tighten the nut until the gap measured with feeler gauges is as follows:

Type	Clearances
LX0260, LX0330, LX0430	0.15 mm (0.006")
LX0110, LX0140, LX0180	0.10 mm (0.004")
LX0030, LX0055	0.07 mm (0.003")

- Fit the nut (920.0) and lock up to the adjusting nut. Recheck the clearance of the casing impeller
- With o-ring (412.0) in place, fit the sealing nut (920.5) - on the LX0110 this also acts as the locking nut
- Secure the valve plate flap onto the port plate using the retainer. Ensure the flap covers all the holes in the port plate
- Fit the o-ring (412.1) and dowel (562.0) to the end casing and fasten the port plate to it using the countersunk screw (906.2)

- Fit second o-ring (412.1) to the impeller casing and fasten the end casing assembly to it ensuring the port faces are level

Overhaul

Busch service will only accept vacuum pumps that come with a completely filled in and legally binding signed "Declaration of Contamination" (form downloadable from www.busch-vacuum.com).

Removal from Service

Temporary Removal from Service

- Prior to disconnecting pipes/lines make sure that all pipes/lines are vented to atmospheric pressure

In case water is being used as operating fluid and the ambient temperatures can fall below 0 °C or the vacuum pump is scheduled to be shut down for more than 12 weeks:

- ◆ Drain the water

In case water is being used as operating fluid, the ambient temperatures can fall below 0 °C and the water is not meant to be drained:

- ◆ Make sure the water sufficiently provided with antifreeze

Recommissioning

- Observe the chapter Installation and Commissioning (→ page 5)

Dismantling and Disposal

- Make sure that materials and components to be treated as special waste have been separated from the vacuum pump
- Make sure that the vacuum pump is not contaminated with harmful foreign material

According to the best knowledge at the time of printing of this manual the materials used for the manufacture of the vacuum pump involve no risk.

- Dispose of the vacuum pump as scrap metal

Spare Parts

When ordering spare parts from Busch please quote the following:

- Pump type / model number
- Pump serial number
- Pump ID number
- Part number
- Description of part

Troubleshooting



WARNING

Risk of electrical shock, risk of damage to equipment.

Electrical installation work must only be executed by qualified personnel that knows and observes the following regulations:

- IEC 364 or CENELEC HD 384 or DIN VDE 0100, respectively,
- IEC-Report 664 or DIN VDE 0110,
- BGV A2 (VGB 4) or equivalent national accident prevention regulation.



CAUTION

During operation the surface of the vacuum pump may reach temperatures of more than 70 °C.

Risk of burns!

Let the vacuum pump cool down prior to a required contact or wear heat protection gloves.

Problem	Possible Cause	Remedy
The vacuum pump does not reach the usual pressure The drive motor draws a too high current (compare with initial value after commissioning) Evacuation of the system takes too long	The vacuum system or suction line is not leak-tight	Check the hose or pipe connections for possible leak
	The operating liquid is too warm (the characteristic curves are based on 15 °C warm water as operating liquid, with higher temperatures the achieved pressure and the flow rate deteriorate)	Reduce the temperature of the operating liquid
	The mechanical seal leaks	Replace the mechanical seal
	Gas or liquid channels are blocked	Dismantle and clean the vacuum pump
	In case a screen is installed in the suction connection (a): The screen in the suction connection (a) is partially clogged	Clean the screen If cleaning is required too frequently install a filter upstream
	The filter on the suction connection (a) is partially clogged	Clean or replace the inlet air filter, respectively
	Partial clogging in the suction, discharge or pressure line	Remove the clogging
	Long suction, discharge or pressure line with too small diameter	Use larger diameter
	Internal parts are worn or damaged	Repair the vacuum pump (Busch service)
The gas conveyed by the vacuum pump smells displeasing	Process components evaporating under vacuum	Check the process, if applicable
The vacuum pump does not start	The drive motor is not supplied with the correct voltage or is overloaded	Supply the drive motor with the correct voltage
	The drive motor starter overload protection is too small or trip level is too low	Compare the trip level of the drive motor starter overload protection with the data on the nameplate, correct if necessary
	One of the fuses has blown	Check the fuses
	Version with alternating current motor: The drive motor capacitor is defective	Repair the drive (Busch service)
	The connection cable is too small or too long causing a voltage drop at the vacuum pump	Use sufficiently dimensioned cable

	The vacuum pump or the drive motor is blocked	<p>Make sure the drive motor is disconnected from the power supply</p> <p>Remove the fan cover</p> <p>Try to turn the drive motor with the vacuum pump by hand</p> <p>If the vacuum pump is blocked:</p> <p>Repair the vacuum pump (Busch service)</p>	
	The drive motor is defective	Replace the drive motor (Busch service)	
The vacuum pump is blocked	Solid foreign matter has entered the vacuum pump	<p>Repair the vacuum pump (Busch service)</p> <p>Make sure the suction line is equipped with a screen</p> <p>If necessary additionally provide a filter</p>	
	Corrosion in the vacuum pump from remaining condensate	<p>Repair the vacuum pump (Busch service)</p> <p>Check the process</p>	
	Corrosion between the rotor (h) and the housing (g)	Eliminate by use of anti-rust liquid	
	Ice in the vacuum pump The operating liquid is congealed	<p>Carefully warm up the vacuum pump</p> <p>Defrost the operating liquid</p>	
	Version with three-phase motor: The vacuum pump was run in the wrong direction	<p>Repair the vacuum pump (Busch service)</p> <p>When connecting the vacuum pump make sure the vacuum pump will run in the correct direction (→ page 8: Installation)</p>	
The vacuum pump starts, but labours or runs noisily or rattles The drive motor draws a too high current (compare with initial value after commissioning)	Loose connection(s) in the drive motor terminal box Version with three-phase-motor: Not all drive motor coils are properly connected The drive motor operates on two phases only	<p>Check the proper connection of the wires against the connection diagram</p> <p>Tighten or replace loose connections</p>	
	The operating liquid level is too high	Adjust the regulating valves	
	Density or viscosity of the operating liquid too high	<p>The performance data is based on water (1000 kg/m³, 1 mm²/s), higher density or viscosity require higher shaft power</p> <p>Provide a different operating liquid or a stronger drive motor</p>	
	Friction between the rotor and the front of the housing	Disassemble the vacuum pump, clean it and adjust to proper clearances	
	Version with three-phase motor: The vacuum pump runs in the wrong direction	Verification and rectification → page 5: Installation and Commissioning	
	Foreign objects in the vacuum pump Stuck bearings	Repair the vacuum pump (Busch service)	
	The vacuum pump runs very noisily	Defective bearings	Repair the vacuum pump (Busch service)
		The vacuum pump cavitates (periodic formation and collapsing of steam bubbles in the operating liquid; → page 5: Installation and Commissioning)	<p>Increase the working pressure (vacuum relief valve) or decrease the temperature of the operating liquid</p> <p>In case of suction of condensable vapours: make sure that enough non condensable gas is conveyed along</p> <p>CAUTION: continuous operation under cavitation will destroy the vacuum pump</p>
	Insufficient air ventilation	<p>Make sure that the cooling of the vacuum pump is not impeded by dust/dirt</p> <p>Clean the fan cowling, the fan wheel, the ventilation grille and the cooling fins</p> <p>Install the vacuum pump in a narrow space only if sufficient ventilation is ensured</p>	

Ambient temperature too high	Observe the permitted ambient temperatures
Temperature of the inlet gas too high	Observe the permitted temperatures for the inlet gas
Insufficient gas transfer	
Mains frequency or voltage outside tolerance range	Provide a more stable power supply
Partial clogging of filters or screens Partial clogging in the suction, discharge or pressure line	Remove the clogging
Long suction, discharge or pressure line with too small diameter	Use larger diameter

Vacuum Pumps and Systems

Busch GVT Ltd. Unit A Westmere Drive. Crewe Business Park. Crewe Cheshire CW1 6ZD



EU Declaration of Conformity

This Declaration of Conformity and the CE-mark affixed to the nameplate are valid for the machine within the Busch scope of delivery. This Declaration of Conformity is issued under the sole responsibility of the manufacturer.

When this machine is integrated into a superordinate machinery the manufacturer of the superordinate machinery (this can be the operating company, too) must conduct the conformity assessment process for the superordinate machine or plant, issue the Declaration of Conformity for it and affix the CE-mark.

The manufacturer

**Busch GVT Ltd.
Westmere Drive
Crewe Business Park
Crewe
Cheshire, CW1 6ZD**



declare that the machine(s): **Dolphin LX 0030 B – Dolphin LX 0430 B
Dolphin LA 0053 A – Dolphin LA 5109 A
Dolphin LB 0063 A – Dolphin LB 4409 A
Dolphin LM 0100 A – Dolphin LM 0800 A
Dolphin LT 0130 A – Dolphin LT 0750 A
Dolphin VL 0100 A – Dolphin VL 0800 A**

with a serial number from **600014...** to **600024...**

has (have) been manufactured in accordance with the European Directives:

- 'Machinery' 2006/42/EC
- 'Electromagnetic Compatibility' 2014/30/EU
- 'Motors (LVD)' 2014/35/EU

and following the standards:

Standard	Title of the Standard
Harmonised Standards	
EN ISO 12100:2011-03	Safety of machinery- Basic concepts, general principles of design – Part 1 and 2
EN ISO 13857 : 2008-06	Safety of machinery- Safety distances to prevent hazard zones being reached by the upper and lower limits.
EN 1012-2 : 2011-12	Compressor and vacuum pumps - safety requirements part 1 and 2
EN ISO 2151 : 2009-01	Acoustics – Noise test code for compressors and vacuum pumps- engineering method (Grade 20).
EN 60204-1: 2007-06	Safety of machinery- Electrical equipment of machines- Part1: General requirements
EN 61000-6-1:2007-10 EN 61000-6-2:2003-03	Electromagnetic compatibility (EMC)- Generic immunity standards
EN 61000-6-3:2007-09 EN 61000-6-4:2007-09	Electromagnetic compatibility (EMC)- Generic emissions standards

Person authorised to compile the technical file:

Graham Moir
Busch GVT Ltd.
Westmere Drive
Crewe Business Park
Crewe
Cheshire, CW1 6ZD

Crewe, 19/04/2017

Tracey Sellers, General Manager

Busch GVT Ltd.

Tel: 01260 274721 Fax: 01260 276965 www.busch-gvt.co.uk e-mail sales@busch-gvt.co.uk

Amsterdam Barcelona Basel Crewe Brussels Dublin Gothenburg Helsinki Istanbul Copenhagen Kuala Lumpur Milan Maulburg

Melbourne Montreal Moscow New York New Plymouth Oslo Paris San Jose Sao Paulo Seoul Singapore Taipei Telford Tokyo Vienna

Sectional Drawings and Spare Parts Lists

LX 0030 B to LX 0055 B

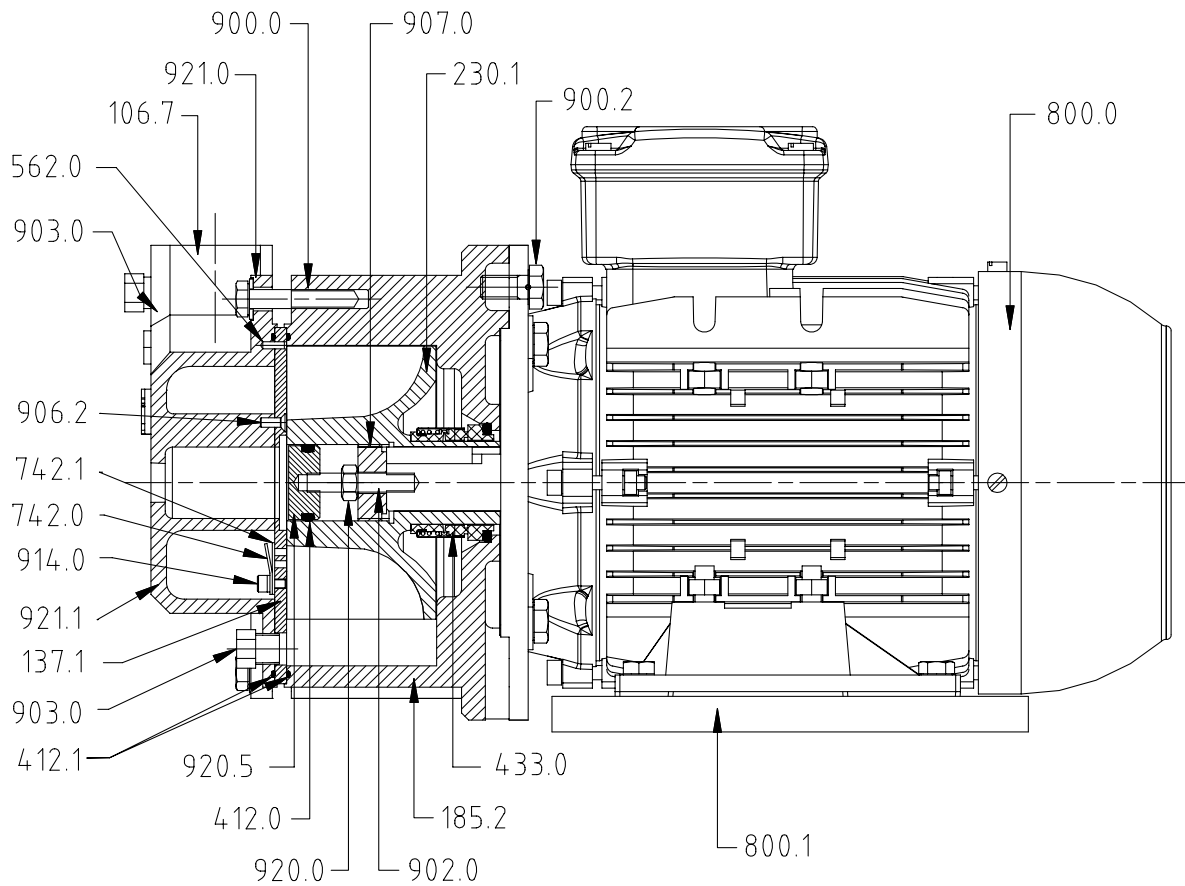

106.7	End casing
137.1	Port plate
185.2	Impeller casing
230.1	Impeller
412.0	O-ring
412.1	O-ring
433.0	Mechanical seal
562.0	Dowel
742.0	Valve plate retainer
742.1	Valve
800.0	Motor
800.1	Motor packer

900.0	Set screw
900.2	Set screw
902.0	Stud
903.0	Drain plug
906.2	Countersunk screw
907.0	Adjusting nut
914.0	Cap screw
920.0	Nut
920.5	Sealing Nut
921.0	Washer
921.1	Washer

LX 0110 B to LX 0430 B

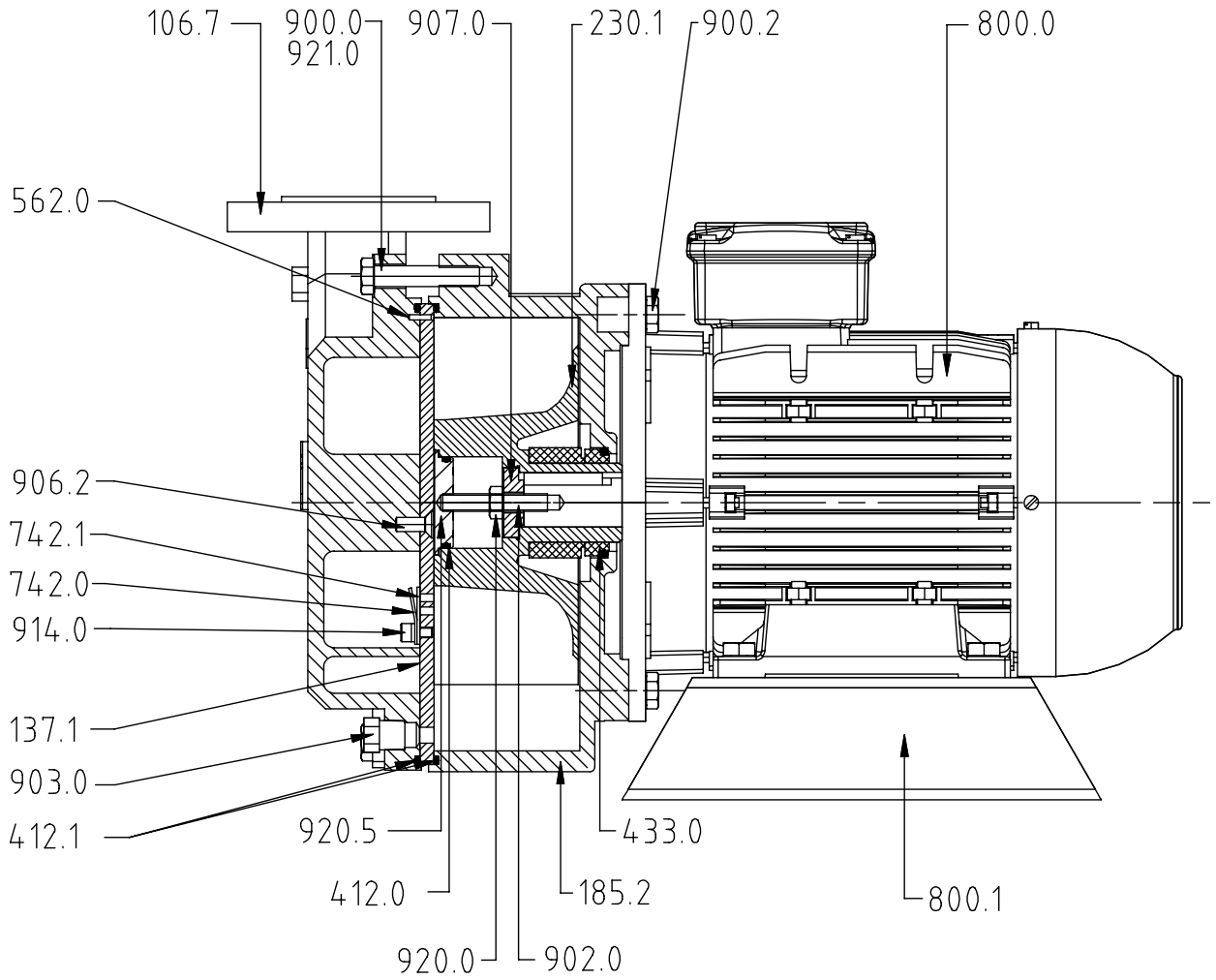

- 106.7 End casing
- 137.1 Port plate
- 185.2 Impeller casing
- 230.1 Impeller
- 412.0 O-ring
- 412.1 O-ring
- 433.0 Mechanical seal
- 562.0 Dowel
- 742.0 Valve plate retainer
- 742.1 Valve
- 800.0 Motor
- 800.1 Motor packer

- 900.0 Set screw
- 900.2 Set screw
- 902.0 Stud
- 903.0 Drain plug
- 903.1 Countersunk screw
- 907.0 Adjusting nut
- 914.0 Cap screw
- 920.0 Nut (not required on model LX 0110 B)
- 920.5 Sealing Nut
- 921.0 Washer

Technical Data

For motor connection parameters see nameplate

Type	Frequency [Hz]	Nominal motor rating [kW]	Speed [min ⁻¹]	Volume flow [m ³ /h]	Sound pressure level (EN ISO 2151) [dB(A)]	Dry weight [kg]	Max. gas inlet temperature [°C]	Max. Discharge pressure [bar (a)]	Once through pressure ** [L/min]	Max. service liquid temperature [°C]	Ultimate pressure [1hp a abs = mbar abs]
LX 0030 B	50	0.75	2900	24	70	~25	80	2	3	40	33
	60	1.1	3500	30		~25					
LX 0055 B	50	1.5	2900	45	70	~30	80	2	5	40	
	60	2.2	3500	55		~33					
LX 0110 B	50	2.2	1450	87	70	~55	80	2	10	40	
	60	3.0	1750	110		~55					
LX 0140 B	50	3.0	1450	115	70	~65	80	2	12	40	
	60	4.0	1750	140		~70					
LX 0180 B	50	4.0	1450	140	70	~75	80	2	15	40	
	60	5.5	1750	180		~75					
LX 0260 B	50	5.5	1450	220	72	~105	80	2	20	40	
	60	7.5	1750	260		~116					
LX 0330 B	50	7.5	1450	280	72	~132	80	2	25	40	
	60	11	1750	330		~132					
LX 0430 B	50	11	1450	370	72	~190	80	2	30	40	
	60	15	1750	430		~198					

* Average flow for once through operation. reduce by 50 % for partial recovery.

** Consult Busch GVT for motor power ratings for high discharge pressures.

Australia

Busch Australia Pty. Ltd.
30 Lakeside Drive
Broadmeadows, Vic. 3047
Tel: (03) 93 55 06 00
Fax: (03) 93 55 06 99

Austria

Busch Austria GmbH
Industriepark Nord
2100 Korneuburg
Tel: 02262 / 756 65-0
Fax: 02262 / 756 65-20

Belgium

Busch N.V./Busch SA
Kruinstraat 7
9160 Lokeren
Tel: (0)9 / 348 47 22
Fax: (0)9 / 348 65 35

Brazil

Busch do Brasil Ltda.
Rod. Edgard Máximo Zambotto, Km 64
13240-000 Jarinu-SP
Tel: (55) 11-4016 1400/5277
Fax: (55) 11-4016 5399

Canada

Busch Vacuum Technics Inc.
1740, Boulevard Lionel Bertrand
Boisbriand (Montréal)
Québec J7H 1N7
Tel: 450 435 6899
Fax: 450 430 5132

Chile

Busch Chile S. A.
Calle El Roble N° 375-G
Lampa - Santiago
Tel: (56-2) 7387092
Fax: (56-2) 7387092

China

Busch Vacuum (Shanghai) Co., Ltd
No.5, Lane 195 Xipu Road
Songjiang Industrial Estate East New Zone
Shanghai 201611 PRC
Tel: +86 (0)21 67600800
Fax: +86 (0)21 67600700

Czech Republic

Busch Vakuum s.r.o.
Pražákova 10
619 00 Horní Heršpice
Brno
Tel: +420 543 42 48 55
Fax: +420 543 42 48 56

Denmark

Busch Vakuumteknik A/S
Parallevej 11
8680 Ry
Tel: +45 87 88 07 77
Fax: +45 87 88 07 88

Finland

Busch Vakuumteknik Oy
Sinikellontie 4
01300 VANTAA
Tel: 09 774 60 60
Fax: 09 774 60 666

France

Busch France S.A.
Parc Technologique
de Bois Chaland CE 2922
91029 Evry Cedex
Tel: 01 69 89 89 89
Fax: 01 60 86 16 74

Germany

Dr.-Ing. K. Busch GmbH
Schauinslandstr. 1
79689 Maulburg
Tel: (0 76 22) 6 81-0
Fax: (0 76 22) 6 81-194
e-mail: info@busch.de

Dr.-Ing. K. Busch GmbH
Niederlassung Nord
Ernst-Abbe-Str. 1-3
25451 Quickborn
Tel: (0 41 06) 7 99 67-0
Fax: (0 41 06) 7 99 67-77

Dr.-Ing. K. Busch GmbH
Niederlassung West
Nordring 35
64807 Dieburg
Tel: (0 60 71) 92 82-0
Fax: (0 60 71) 14 71

Dr.-Ing. K. Busch GmbH
Außenstelle Neuenrade
Breslauer Str. 36
58809 Neuenrade
Tel: (0 23 92) 50 29 92
Fax: (0 23 92) 50 72 11

Dr.-Ing. K. Busch GmbH
Niederlassung Süd-Ost
Gewerbestraße 3
90579 Langenzenn
Tel: (09 01) 90 25-0
Fax: (09 01) 90 25-25

Dr.-Ing. K. Busch GmbH
Außenstelle Zella-Mehlis
Am Rain 11
98544 Zella-Mehlis
Tel: (0 36 82) 46 92 71
Fax: (0 36 82) 46 92 73

Dr.-Ing. K. Busch GmbH
Außenstelle Meitingen-Ostendorf
Grüntenweg 8
86405 Meitingen-Ostendorf
Tel: (0 82 71) 426-341
Fax: (0 82 71) 426-342

India

Busch Vacuum India Pvt Ltd.
Plot No. 110, Sector 7
PCNTDA, Bhosari
Pune 411026, Maharashtra
Tel: (0)206410 2886
Fax: (0)202711 2838

Ireland

Busch Ireland Ltd.
A10-11 Howth Junction Business Centre
Kilbarrack, Dublin 5
Tel: 00353 1 832 1466
Fax: 00353 1 832 1470

Israel

Busch Israel Ltd.
1 Mevo Sivan Street
Qiryat Gat 82022, Israel
Tel: +972 (0)8 6810485
Fax: +972 (0)8 6810486

Italy

Busch Italia S.r.l.
Via Ettore Majorana, 16
20054 Nova Milanese
Tel: 0362 370 91
Fax: 0362 370 999

Japan

Nippon Busch K.K.
1-23-33, Megumigaoka
Hiratsuka City, Kanagawa
Japan 259-1220
Tel: 0463-50-4000
Fax: 0463-50-4004

Korea

Busch Korea Ltd.
392-1 Yangji-Ri, Yangji-Myun,
Yongin-si, Kyunggi-Do
Tel: (031) 321-8114
Fax: 031) 321 4330

Malaysia

Busch (Malaysia) Sdn Bhd.
6 Jalan Taboh 33/22
Shah Alam Technology Park
Section 33
40400 Shah Alam
Selangor D. E.
Tel: 03 5122 2128
Fax: 03 5122 2108

Mexico

Busch Vacuum Mexico S de RL de CV
Tlaquepaque 4865, Los Altos
Monterrey, Nuevo Leon
Mexico 64370
Tel: (81) 8311-1385
Fax: (81) 8311-1386

Netherlands

Busch B.V.
Pompomolenlaan 2
3447 GK Woerden
Postbus 2091
3440 DB Woerden
Tel: (0)348 - 462300
Fax: (0)348 - 422939

New Zealand

Busch New Zealand Ltd.
Unit D, 41 Arrenway Drive
Albany 0632
Auckland
Tel: 09 414 7782
Fax: 09 414 7783

Norway

Busch Vakuumteknikk AS
Hestehagen 2
1440 Drøbak
Tel: 64 98 98 50
Fax: 64 93 66 21

Poland

Busch Polska Sp. z o.o.
Ul. Chopina 27
87800 Włocławek
Tel: (054) 2315400
Fax: (054) 2327076

Portugal

Busch Ibérica S.A., Sucursal em Portugal
Zona Industrial Raso de Travassô, Fração B, Armazém 2
3750-753 Agueda
Aveiro, Portugal
Tel: +351 234 648 070
Fax: +351 234 648 068

Singapore

Busch Vacuum Singapore Pte Ltd
20 Shaw Road
#01-03 Ching Shine Building
Singapore 36 79 56
Tel: (65) 6488 0866
Fax: (65) 6288 0877

Spain

Busch Ibérica S.A.
C/ Jaume Ferran, 6-8
Pol. Ind. Coll de la Manyà
08403 Granollers
Tel: +34 93 861 61 60
Fax: +34 93 840 91 56

Sweden

Busch Vakuumteknik AB
Bråta Industriområde
435 33 Mölnlycke
Tel: 031 - 338 00 80
Fax: 031 - 338 00 89

Switzerland

Busch AG
Waldweg 22
4312 Magden
Tel: 061 / 845 90 90
Fax: 061 / 845 90 99

Taiwan

Busch Taiwan Corporation
1F. No. 69, Sec. 3, Beishen Rd.
Shenkeng Township,
Taipei Country,
Taiwan (222), R.O.C
Tel: (02) 2662 0775
Fax: (02) 2662 0796

Thailand

Busch Vacuum (Thailand) Co., Ltd.
888/30 Moo19, Soi Yingcharoen, Bangplee-Tamru Rd.,
Bangpleeyai, Bangplee, Samutprakarn 10540 Thailand
Tel: (66) 2-382-5428
Fax: (66) 2-382-5429

Turkey

VAKUTEK
Emlak Kredi Ishani No: 179
81130 Üsküdar-Istanbul
Tel: (216) 310 0573
Fax: (216) 343 5126

United Kingdom

Busch (UK) Ltd
Hortonwood 30-35
Telford Shropshire TF1 7YB
Tel: 01952 677 432
Fax: 01952 677 423

USA

Busch, Inc.
516-B Viking Drive
Virginia Beach, VA 23452
Tel: (757) 463-7800
Fax: (757) 463 7407

Semiconductor Vacuum Group Inc.
Morgan Hill, CA 95037
Tel: (408) 955 1900
Fax: (408) 955 0229